

WaterMaker^{FIVE}®



Installation Guide Owners Manual

Nimbus
WATER SYSTEMS

41840 McAlby Court, Suite A
Murrieta, CA 92562
800-451-9343, FAX 951-894-2801
www.nimbuswater.com

A**OWNERS MANUAL**
About This System

Congratulations on your purchase of the WaterMaker Five reverse osmosis system. When properly maintained, this system will provide you with years of trouble-free service. The next sections contain important information on the proper care and maintenance of your system, please take a few minutes to read through this information.

B**OWNERS MANUAL**
Maintenance Schedule

The cartridges in this system must be replaced on a regular basis to maintain efficiency and to safeguard water quality. Each system is equipped with:

1. A four-stage reverse osmosis desalinators containing a sediment filter, a GAC filter, a reverse osmosis membrane and a GAC post-membrane filter.
2. An inline, post-tank GAC filter cartridge attached to the faucet line.

These cartridges work together to remove potential contaminants from your tap water and must be replaced every 6-12 months. Any significant change in performance of the system should be investigated promptly to avoid secondary damage or deterioration to other parts of the system.

Component	Interval	Indications for Service
4-Stage Desalinators	12 months	Significant increase in the level of total dissolved solids (TDS) in the product water, as determined by a conductivity meter. System takes longer than 3 hours to fill a completely drained tank.
In-line post filter	6-12 months	Off taste or odor in the product water

C

OWNERS MANUAL Replacements

Replacement part numbers are indicated on the side of each cartridge. The table below lists cartridge replacement part numbers as well as part numbers for other parts you may need to maintain your unit.

Item	Description	Part No
A	4-Stage Desalinator	104361
B	In-line post tank filter	102972
C	Air-gap faucet	103242
D	Cartridge retainer clip	104609
E	Drain saddle assembly	100552
F	Feed valve	104503
G	Tank strap w/clip	104048
H	Tank with valve	104096
I	Inlet shut-off	107074
(not shown)	Automatic shut-off valve	105684

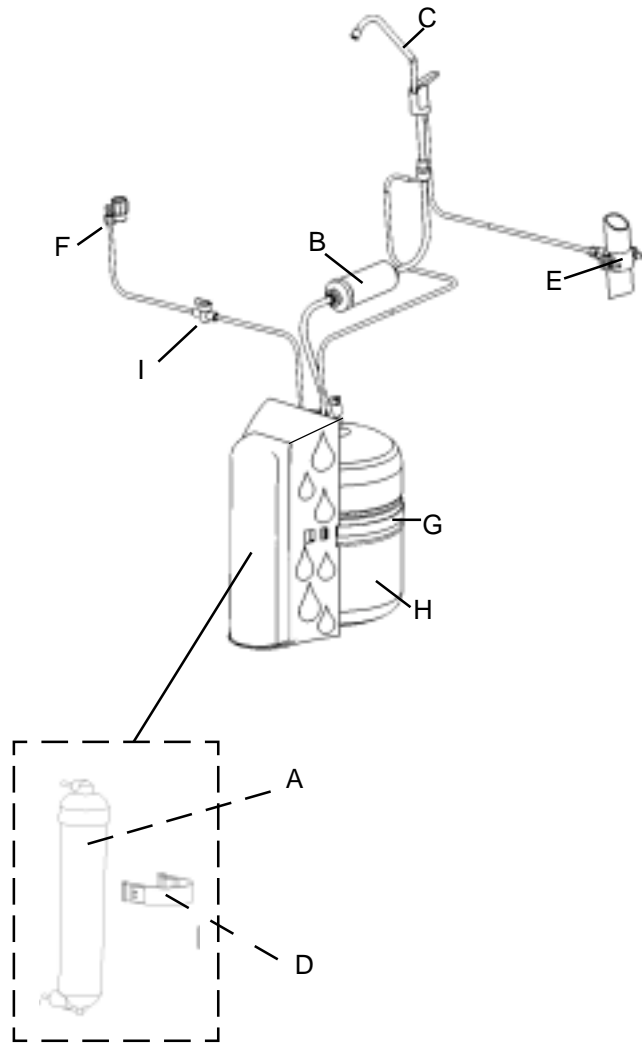

D**OWNERS MANUAL**
System Warranty

The Limited Warranty extends to the original purchaser of the system. This warranty covers all parts and factory labor needed to repair any Manufacturer-supplied item that proves to be defective in material, workmanship or factory preparation. The above-mentioned warranty applies for the first full calendar year from date of purchase. These defective items are subject to the following exclusions: membranes, filters, O-rings, and all other parts or components that require regular replacement as a result of ordinary usage.

Disclaimers This Warranty applies only if the system is installed and used in compliance with the instructions enclosed with the system.

This Warranty does not cover the costs of repairs or adjustments to the unit that may be needed because of the use of improper parts, equipment or materials. This Warranty does not cover repairs required due to unauthorized alterations of the unit, or failure of a unit caused by such alterations or by unauthorized repairs.

The Warranty does not cover malfunctions of the unit due to tampering, misuse, alteration, lack of regular maintenance, misapplication, fouling due to hydrogen sulfide or iron, scaling from excessive hardness, turbidity greater than 1.0 NTU, Silt Density Index (SDI) greater than 5.0 SDI, or excessive membrane hydrolysis due to chlorine levels in excess of 0.5 ppm. In addition, damage to the unit due to fire, accident, negligence, act of God, or events beyond the control of the Manufacturer are not covered by this warranty.

Incidental and Consequential Damages The Manufacturer does not assume responsibility for payment of incidental and consequential damages as a result of the failure of this unit to comply with express or implied warranties, such as lost time, inconvenience, damage to personal property, loss of revenue, commercial losses, postage, travel, telephone expenditures, or other losses of this nature. Some states do not allow the exclusion or limitation of incidental or consequential damages, so this exclusion may not apply to you.

Owner's Warranty Responsibilities Under the provisions of the Warranty, the owner is expected to schedule maintenance, as described in this Manual. Neglect, improper maintenance, abuse, or unapproved modifications may invalidate the Warranty. Should your unit develop a defect or otherwise fail to perform in accordance with this warranty, you should contact the dealer from whom the product was originally purchased.

Implied Warranties The implied at-law warranties of merchantability and fitness for a particular purpose shall terminate on the date one year after the date of purchase. Note: some states do not allow limitations on how long an implied warranty lasts, so the above limitations may not apply to you.

Other Rights This Warranty gives you specific legal rights and you may also have other rights which vary from state to state.

D**OWNERS MANUAL**
System Information

Please fill out the form below and retain for future reference.

Model: WaterMaker Five

Serial No: _____

Install Date: _____

Sold by: _____

Installed By: _____

Service Center
Phone Number: _____

Performance Specifications

	Membrane	System w/Tank
Production	40 GPD (151 LPD)	21.6 GPD (81.8 LPD)
TDS Rejection	95%	95%
Recovery ¹	26.3%	17%
Brine to Product	2.8:1	4.86:1

¹ The percentage of the feed water available as reverse osmosis treated water under normal operating conditions.

Tested at 60 psig (4 bar), 500ppm TDS municipal water, 77°F (25°C)

Feed Water Requirements

Pressure	40-80 psi (275 kPa - 552 kPa)
Temp	40°F - 100°F (4°C - 38°C)
TDS	<2000 mg/L
Chlorine	<1.0 mg/L
Turbidity	<1 NTU
SDI	<5
pH	4-8

Feed water must be potable, municipal water. Must be free of potential membrane foulants such as Iron, Hydrogen Sulfide and Manganese.

Dimensions and Weight

System - 9.72" W x 13.75" D x 15.38" H (24.7 x 34.9 x 39.1 cm), 11 lbs. (5 kg.)
Shipping Box - 14.5"L x 11.25"W x 20"H (36.8 x 28.6 x 50.8 cm), 13.7 lbs. (6.2 kg.)

1

INSTALLATION Overview

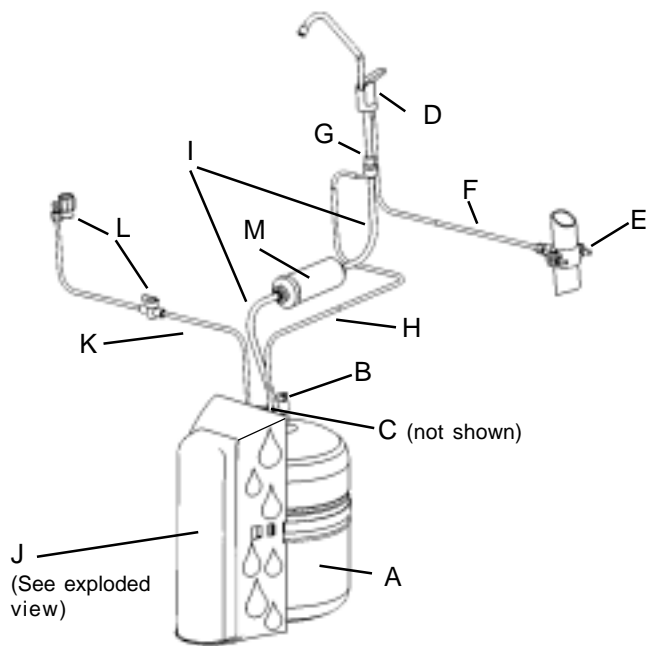

- A. Product water storage tank
- B. Tank valve
- C. Tank tubing (3/8" white)
- D. Air-gap faucet
- E. Drain connection assembly
- F. Drain tubing (3/8" white)
- G. Quick connect fitting
- H. Drain tubing (1/4" black)
- I. Faucet tubing (3/8" blue)
- J. Four-stage desalinator
- K. Feed water tubing (1/4" green)
- L. Inlet fitting with shut-off
- M. Carbon post-filter

J
(See exploded view)

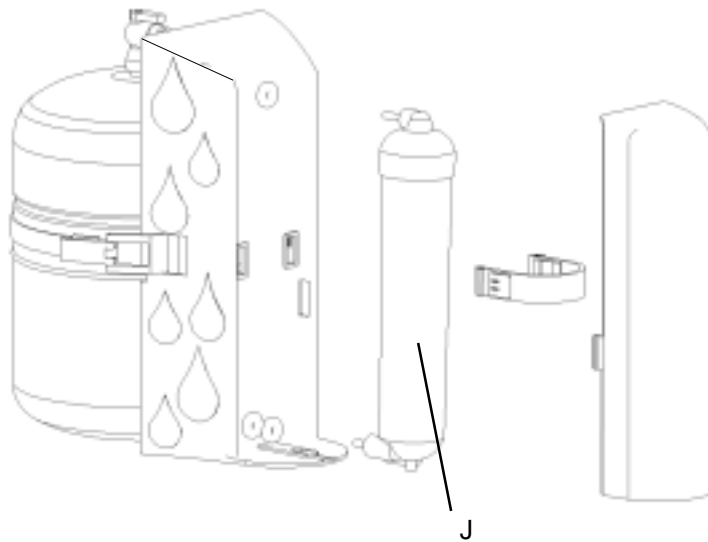

This system has been designed for installation by a licensed professional such as a contractor or plumber. Proper completion of this installation will require basic familiarity with standard sink plumbing and proper use of common hand and power tools. Improperly installed systems could result in water damage due to leaks or flooding. Do not use with water that is microbiologically unsafe or of unknown quality.

2

INSTALLATION

Parts

WaterMaker Five System

- A. 4-stage desalinator
- B. Inline post filter
- C. Product Water Storage Tank
- D. Air-gap faucet
- E. Drain saddle unit
- F. Feed water connection assembly*
(supplied with shut-off valve attached)

Parts Kit (not shown)

- Ferrule, 1/4" plastic ferrule
- Adapter, 1/2" MPT x 1/2" FPT x 1/8" FPT
- Elbow, 1/4" compression x 1/8" MPT, brass
- Ball valve, 1/4" QC x 1/4" QC
- Tubing insert, 1/4" plastic
- Faucet connector, 3/8" QC
- Flat rubber washer
- Gray rubber cone
- Date of Installation label
- Feed valve warning tag
- Feed shut-off warning label

Tubing

- 4' white 3/8" tubing
(faucet to drain saddle connection)

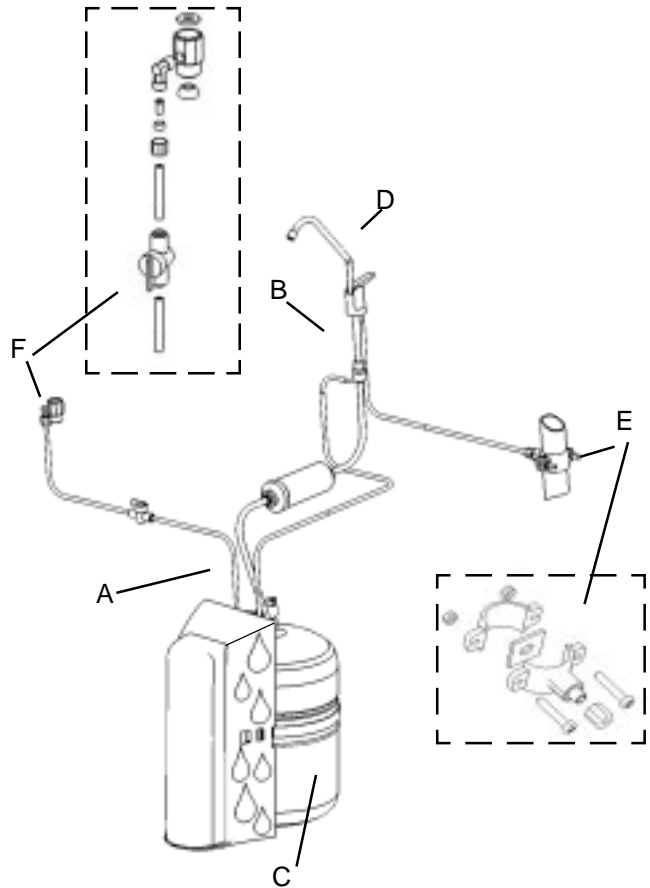

*The feed water connection assembly supplied with this system includes components which represent the most common under-sink plumbing connections currently in use within the United States. If these components do not match the type of connections installed at your location, contact a local hardware or plumbing supplier to obtain the correct fittings.

3

INSTALLATION Drilling the sink

In addition to common hand tools, the following tools are required for drilling through the most common sink materials:

1/4" masonry drill bit
1 1/4" hole saw
7/8" chassis punch

1 1/4" porcelain cutter
Hole saw adapter
Center punch

Hint: Special care should be taken when drilling the faucet hole. A clean hole can be cut in a short period of time, but any attempt to rush the process will result in chips and scratching. On some sinks there may be ridges on the underside of the sink. You must avoid these ridges or other obstructions to insure an adequate flat surface for installation of the faucet nut and washer.

When performing installations that call for locating the faucet on the counter instead of the sink, ensure that adequate space is available underneath to accommodate the faucet subassembly.

Formica or Wooden Counter

1. Drill a 1/4" hole with hole saw or flat (spade) wood bit.
2. Clean off sawdust.

Enamel, Porcelain-Over-Steel, or Cast Iron Sink

1. With drill motor place 1/4" masonry drill bit at selected location. Before starting rotation, firmly apply downward pressure until a slight crunching sound is heard. This will fracture a small area of the enamel/porcelain and prevent the bit from "walking".
2. Drill the 1/4" pilot hole.
3. With the pilot hole as a guide, use a 1 1/4" porcelain cutter to cut through the porcelain/enamel only. Stop the drill once the metal is exposed.
4. Once again using the pilot hole as a guide, use the 1 1/4" hole saw to cut through the metal. (The hole saw is slightly smaller than the porcelain cutter so the teeth of the saw will not chip the enamel/porcelain).

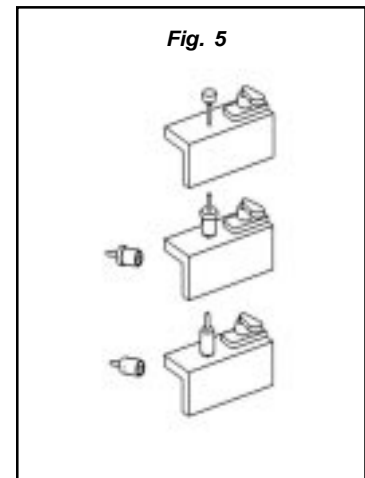

CAUTION - DO NOT BOTTOM OUT THE DRILL ON CERAMIC SURFACE.

5. Clean off the sink and wipe the area clean. Be sure all metal chips are removed as they can stain porcelain very quickly.

3

INSTALLATION

Drilling the sink

(continued)

Tile Sink or Counter

1. Follow procedures 1-3 under Enamel, Porcelain, Cast Iron Sink procedures.
2. With the gentle use of the center punch and hammer, break up the ceramic disk to the extent necessary to remove it. Remove the ceramic disk.
3. Use the 1¼" hole saw or wood drill to continue the hole through the wooden support. Clear away the debris.

Stainless Steel Sink

1. Use a center punch and hammer to mark the sink surface for drilling.
2. Drill a starter hole with a 1/8" high speed drill bit.
3. Enlarge the starter hole with a 7/16" high speed drill bit.
4. Make a 1¼" faucet hole with the chassis punch by placing the male cutter of the chassis punch under the 7/16" pilot hole, insert driving bolt through female die and pilot hole into the male die. Tighten driving bolt to cut the faucet hole.
5. Use a round file to clean up any rough edges. Clean up any filings, ensuring that none get into the sink drain or disposal.

4

INSTALLATION

Push Handle Faucet

Determine the most practical under-the-sink location for placement of the WaterMaker Five system. Ensure that the location allows adequate access for cartridge replacement.

1. Place the system in the selected location.
2. Place the rubber seal (1) flush against the base of the faucet.
3. Insert faucet base assembly down through the sink hole.
4. From underneath the sink, push the 1/4" black drain tubing attached to the system onto the 1/4" fitting located on the faucet base.
5. Locate the extra piece of 3/8" white tubing and push one end onto the larger 3/8" fitting located on the faucet base.
6. Slide white plastic spacer (2) open-end-up onto the threaded faucet stem.
7. Loosely thread the 3/8" washer (3) and mounting lock nut (4) onto the threaded stem.
8. Thread faucet quick-connect adapter (5) on to threads of faucet stem. NOTE: This connection should be hand-tightened only. Push end of 3/8" blue tubing (located on the system) onto 3/8" adapter.
9. Position the faucet to the desired handle orientation. Slip the (6) slotted washer between the white plastic spacer and the sink. Securely hand tighten the mounting nut.
10. Firmly insert spout assembly into the top hole of faucet body (approximately 1/4"). You may swivel the faucet left or right.

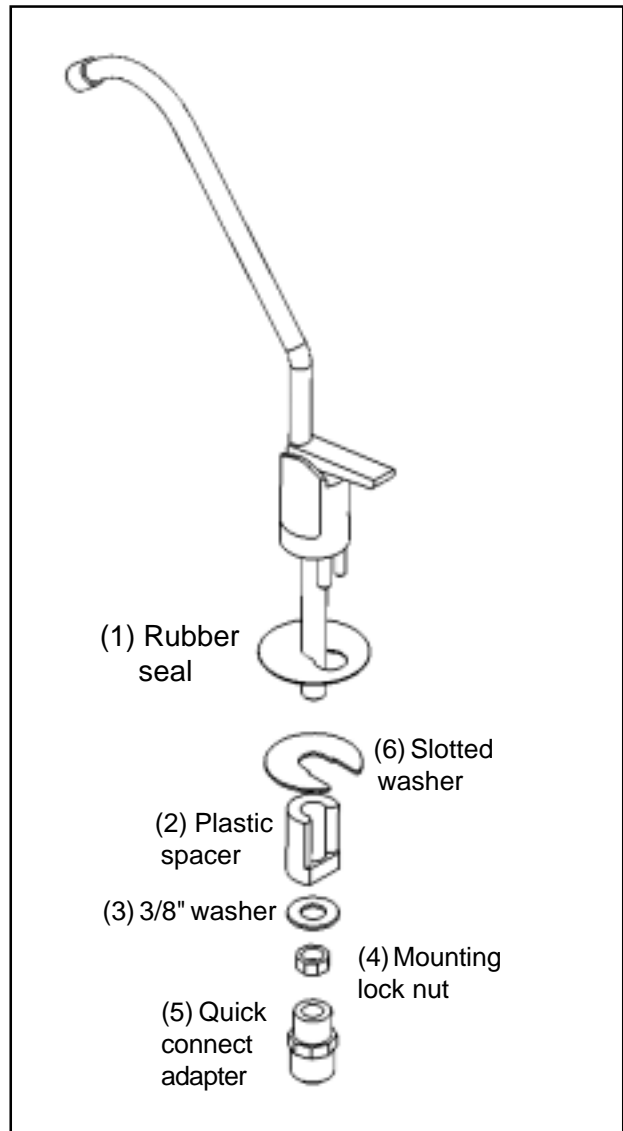

5

INSTALLATION Drain Connection

Note: The drain saddle assembly must be installed before the 'P' trap. Do not install the drain saddle assembly between the 'P' trap and the wall.

1. Position drain saddle assembly (Fig. 3) on drain pipe under sink between the P trap and the sink connection.

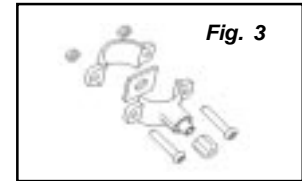

2. Orient the drain saddle so that the connector opening points in the general direction of the planned location for the dispensing faucet.

3. Screw the connector nut onto the drain saddle threaded connector loosely (Fig. 4). Using the connector opening in the side of the drain saddle as a guide, drill a 3/8" hole through the wall of the drain pipe.

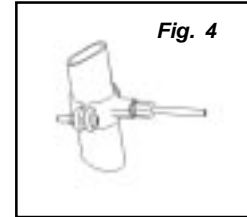

4. Remove drain saddle assembly. Place the adhesive foam pad over the 3/8" hole in the drain pipe. Replace the assembly onto the drain pipe, aligning the hole in the drain with the hole in the drain assembly.

5. Tighten the saddle bolts evenly on both sides until the saddle grips the pipe snugly - do not over-tighten. (Fig.4)

9. Extend the white 3/8" tubing connected to the faucet to the drain saddle assembly. This tubing should follow as direct a path as possible; long runs, looping or deep sags will restrict normal brine flow to the drain. Cut tubing if necessary to ensure the correct length. Connect the white 3/8" tubing

6

INSTALLATION Feed Connection

1. Locate and turn off the angle stop valve on the cold water line feeding the sink. This valve will usually be located under the sink on the pipe coming out of the wall.
2. When the angle stop valve is closed, relieve pressure in the line by opening the cold water tap on the sink.
3. It may be possible to install the feed adapter fitting at either the angle stop valve or at the faucet inlet connector depending on the size and type of fittings at your location. The angle stop valve is preferable because of its easier accessibility. Both options are shown.

Option A - To install the feed adapter at the faucet connector, disconnect the cold water feed line where it connects to the faucet inlet connector. Proceed to step 4.

Option B - To install the feed adapter at the angle stop valve, disconnect the feed line at the angle stop valve. With this end of the water line free, proceed to step 4.

4. Take the 1/4" feed connector valve from the parts kit and install it into the brass feed connector adapter. Use a crescent wrench or open-end wrench to tighten the valve into the adapter. If the feed adapter is to be installed at the faucet inlet connector it may be necessary to install the feed connector valve after step 5 due to limited space.

5. Using the flat and cone washers as necessary, install the feed adapter into the faucet inlet connector or angle stop valve as chosen above. Then reconnect the cold water feed line to the open end of the feed adapter. Tighten all connections securely.

6. Using the green 1/4" tubing located on the system, install the compression nut, plastic ferrule, and plastic tube insert into the open end. Secure the tubing into the feed connector valve. Tighten the tubing retaining nut securely. See Fig.2.

7. Attach the small feed valve warning tag from the parts bag to the feed valve.

5. Attach the Shutoff Warning label to the system so that it is directly visible. Fill out and attach Date of Installation label to side of system.

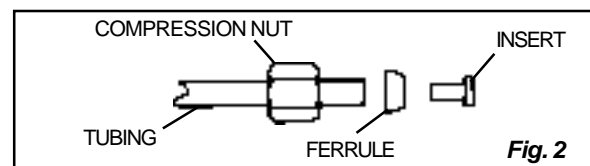
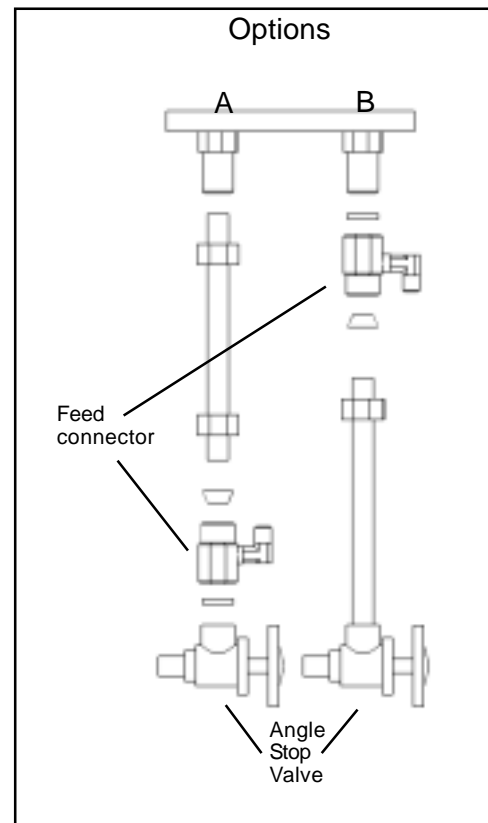

7

INSTALLATION Activation/Flushing

System Activation and Inspection

1. Check all tubing connections to ensure they are firmly seated. CHECK TO SEE THAT THE CARTRIDGE RETAINER CLIP IS PROPERLY ENGAGED. Failure to keep the retaining clip in place will result in accidental leaks and flooding.
2. Open the dispensing faucet at the sink.
3. Open the feed water valve to the system. Observe all tubing and connections for several minutes to detect any leaks. In approximately 5 minutes, (assuming normal feed water pressure) the dispensing faucet should begin dripping. Allow the faucet to run for up to 15 minutes, then close the faucet.
4. Place a pan or other temporary water basin near the drain 'P' trap. Loosen the connector nut holding the 3/8" tube in the drain saddle connector. Pull the tube out of the connector and use the pan to catch any water that may spill. Brine water should be flowing from the tube. Reconnect the tube to the drain saddle and hand-tighten the connector nut.

Initial Flushing Procedure

1. Before the system can be used for drinking water production it must be adequately flushed. Each reservoir tank is dosed with a small amount of powdered sanitizer before shipment, typically a chlorinating agent, in order to ensure tank internal cleanliness. Also, the carbon filter cartridge will release a small amount of carbon fines during the first tankful of flow. This flushing procedure will allow any sanitizer or carbon fines to pass from the system.
2. Initial tank filling will take approximately one hour (based on average feed pressure). When the tank is full, the water pressure will have risen to the point where the automatic shut-off valve inside the system will stop the feed flow through the system. Actuation of the automatic shut-off valve can be determined by either checking for a lack of brine flow to the drain saddle, or by listening very closely near the dispensing faucet for absence of water flow sound through the air gap. When the tank has filled for the first time, it should be left undisturbed for at least 8 hours to ensure proper sanitization.
3. After 8 hours has elapsed, open the dispensing faucet fully and allow the product water to run out to drain at maximum flow. The initial discharge will be dark with the bulk of the carbon particle wash out. There may also be the scent of chlorinated water from the sanitizing agent. When the flow has diminished to a fast drip or small stream, close the dispensing faucet.
4. Fill and flush the tank at least three times prior to use. If necessary, repeat until the chlorination scent has disappeared. It is important that the flush be done at maximum flow (e.g. the tank must be full) to assist in rapid wash out. After this flushing procedure the system is ready for normal use.

8

INSTALLATION CheckList

1. System is located where it will not be subject to physical impacts or rough contact by heavy objects.
2. Feed water pressure to the unit is no less than 40 psi and no greater than 80 PSI.
3. Ensure the plastic retainer clip is fully engaged. The slide locks must snap into place in the slots. If the clip does not snap easily into place through the slots it means the cartridge is not fully inserted into the connectors. Press top or bottom of cartridge to engage connectors until it snaps into place properly.
4. All tubing connections, especially push-in quick connections, are fully inserted.
5. Tubing connected between the faucet and the drain saddle fitting (the fitting attached to the sink drain pipe) runs "downhill" to the drain. There should be no loops or places where water would not flow out to the drain.
6. Feed water valve is open.
7. Within one to two hours after initial application of water pressure, check again for leaks especially at the tank, faucet tubing and connectors. These parts will not see full pressure until approximately 2 hours after the system is activated.
8. Flush three tankfuls of product water to drain. If a chlorine scent persists, repeat flushing procedure in Section 7.

Refer to Section B in this manual portion for a suggested replacement schedule.

Cartridge Replacement

1. Close the feed water shut-off valve.
2. Open the dispensing faucet.
3. Close the dispensing faucet and the tank valve when the water stops flowing.
4. Remove the cover from the front of the system. Remove the retaining clip. Pull the cartridge off the system evenly at top and bottom. Dispose of used cartridge.
6. Install the new cartridge, rocking gently from side to side as necessary until the cartridge tubes are fully engaged in the system connectors. Install the retaining clip, ensuring the slide locks snap into place in the slots. If the clip does not snap easily into place through the slots it means the cartridge is not fully inserted into the connectors. Press top or bottom of cartridge to engage connectors until it snaps into place properly.
7. Open the dispensing faucet.
8. Turn on feed water shut-off valve.
9. Observe system for any leaks, especially at newly replaced cartridge.
10. Close dispensing faucet after water stops running.
11. The system should be flushed at least once as described above under Section 8.

Post Filter Replacement

1. Close the feed water shut-off valve.
2. Open the dispensing faucet.
3. Close the dispensing faucet and the tank valve when the water stops flowing.
4. Locate the inline filter on the faucet line.
5. Remove the red locks from the collets.
6. Remove the tubing by depressing the collet in a downward direction and pulling the blue tubing from the filter.
7. Remove the other side of the feed tubing as described above.

9

MAINTENANCE

Cartridges/Tank

(Continued)

8. Reverse the above steps to install the new inline filter, making sure that the tubing is pressed in as far as possible.
9. Open the dispensing faucet.
10. Turn on feed water shut-off valve.
11. Observe system for any leaks, especially at newly replaced cartridge.
12. Close dispensing faucet after water stops running.
13. The system should be flushed at least once as described above under Section 7.